

Rated voltage: 12 V **Capacity:** 80Ah C₁₀ at 25°C(77°F) to 1.80V per cell

- * Designed service life of 12+ years
- * World-wide compatibility
- * Easy maintenance with low operation cost
- * Easy installing and parameters readings
- * Wide operation temperature range
- * Superior low current discharge performance
- * Better safety performance and reliability
- * Modular and installation design
- * Environmental friendly

Size: 395x105x270mm

Weight: 27 kg

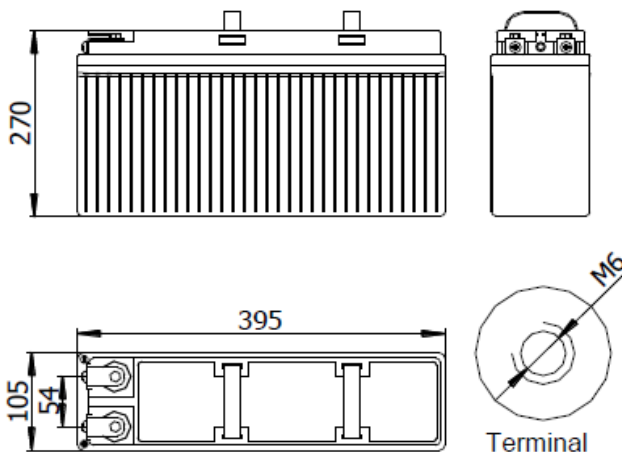

Application:

Telecommunication
 UPS
 Solar and wind power system
 Electric power, nuclear power
 Marine

Company Certificates

ISO 9001:2009
 ISO 14001:2005
 OHSAS 18001:2008



Technical details

Max discharge current:	580A (5sec)	Self-discharge:	less than 8% 90 days @ 25°C (77°F)
Internal resistance (charged):	5.2mΩ @ 25°C(77°F)	Max charge current:	16A
Temperature range		Charge voltage at 25°C	Float: 2.23V, Cycle: 2.35V
Application temperature:	-40°C ~ 50°C(-40°F ~ 122°F)	Terminal output:	M6
Storage:	-20°C ~ 40°C(-4°F ~ 104°F)	Container	ABS
Charge:	-20°C ~ 45°C(-4°F ~ 113 °F)		
Temperature compens.factor:	-3 mV/°C		

Temperature effect on battery capacity: 105 % @ 40°C; 85 % @ 0°C; 60 % @ -20°C

Discharge current (A/25°C, 77°F):

End Voltage	30min	1hr	2hr	3hr	4hr	5hr	6hr	8 hr	10 hr	12hr
1,70	81,6	45,4	29,8	22,7	19,0	14,7	12,3	10,1	8,8	7,5
1,75	77,3	44,2	29,3	22,2	18,7	14,6	12,2	9,9	8,5	7,2
1,80	73,0	43,2	29,0	22,1	18,4	14,4	12,0	9,8	8,3	7,0
1,83	69,6	41,3	28,8	21,8	18,1	14,2	11,8	9,4	8,2	6,9
1,85	67,4	40,2	28,5	21,6	17,9	14,1	11,7	9,3	8,0	6,7

Discharge power (W/25°C, 77°F):

End Voltage	30min	1hr	2hr	3hr	4hr	5hr	6hr	8 hr	10 hr	12hr
1,70	148,0	84,5	57,0	44,2	36,8	29,1	25,8	19,8	17,4	14,6
1,75	141,8	83,0	56,6	43,7	36,6	29,0	25,4	19,8	17,0	14,2
1,80	135,7	82,1	56,3	43,4	36,3	29,0	25,3	19,5	16,8	14,1
1,83	131,5	79,4	56,0	43,0	36,0	28,8	25,0	19,0	16,8	13,9
1,85	128,3	77,4	55,7	42,9	35,8	28,6	24,8	18,9	16,6	13,8

Discharge curves

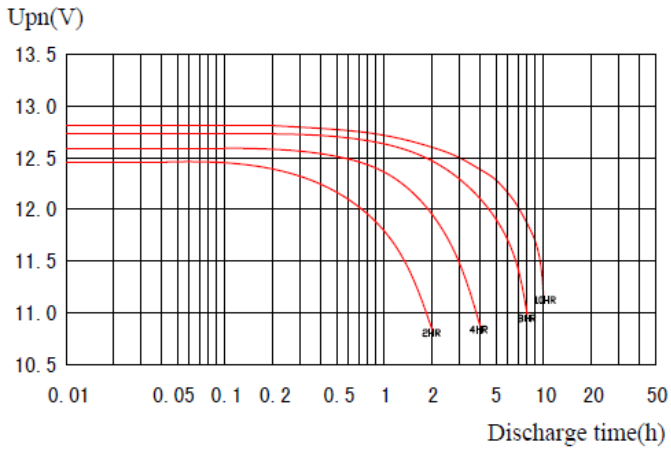

Temperature and capacity relation

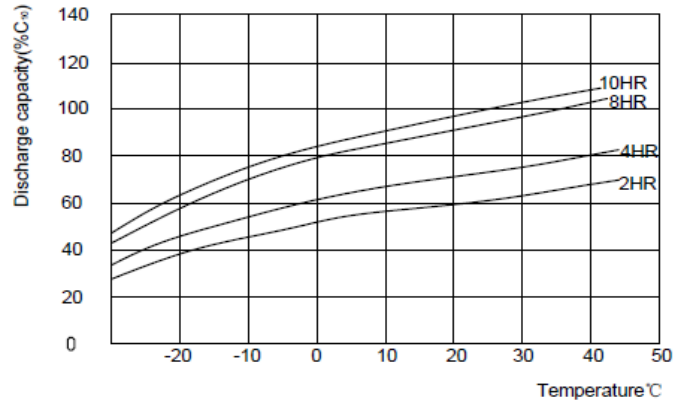

Selfdischarge at different temperature

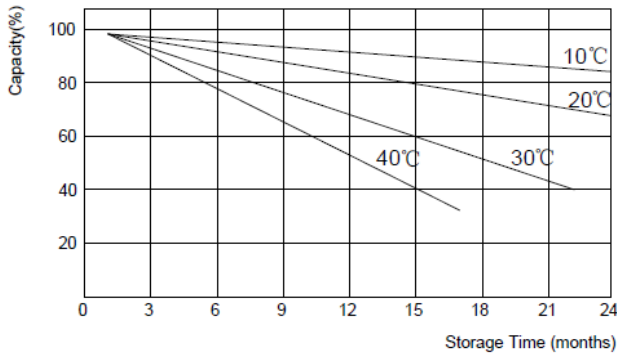

Constant voltage charge characteristic

