

The rechargeable batteries are lead-lead dioxide systems. The dilute sulfuric acid electrolyte is absorbed by separators and plates and thus immobilized. Should the battery be accidentally overcharged producing hydrogen and oxygen, special one-way valves allow the gases to escape thus avoiding excessive pressure build-up. Otherwise, the battery is completely sealed and is, therefore, maintenance-free, leak proof and usable in any position.

Battery Construction

| | | | | | | | | |
|--------------|----------------|----------------|-----------|-------|--------------|----------|------------|---------------|
| Component | Positive plate | Negative plate | Container | Cover | Safety valve | Terminal | Separator | Electrolyte |
| Raw material | Lead dioxide | Lead | ABS | ABS | Rubber | Pb | Fiberglass | Sulfuric acid |

General Features

- Absorbent Glass Mat (AGM) technology for efficient gas recombination of up to 99% and freedom from electrolyte maintenance or water adding.
- Not restricted for air transport-complies with IATA/ICAO Special Provision A67.
- UL-recognized component.
- Can be mounted in any orientation.
- Computer designed lead, calcium tin alloy grid for high power density.
- Long service life, float or cyclic applications.
- Maintenance-free operation.
- Low self discharge.

Dimensions and Weight

Length(mm / inch).....306 / 12.05
 Width(mm / inch).....169 / 6.65
 Height(mm / inch).....210 / 8.26
 Total Height(mm / inch).....234 / 9.21
 Approx. Weight(Kg / lbs).....30 / 66.1

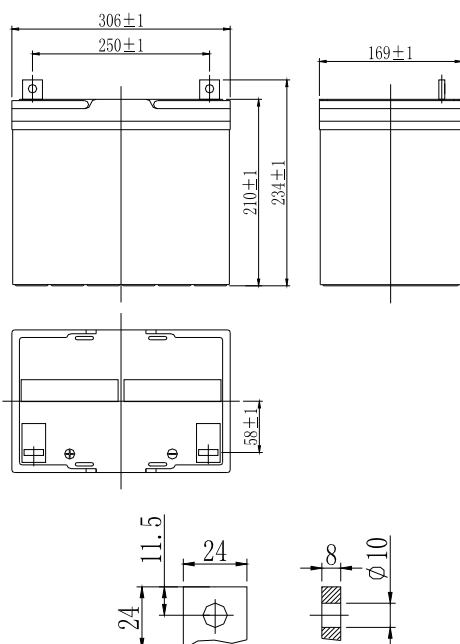

Performance Characteristics

Nominal Voltage12V
 Number of cell6
 Design Life10 years
 Nominal Capacity 77°F(25°C)
 20 hour rate (4.5A, 10.5V)..... 90Ah
 10 hour rate (8.9A, 10.5V)..... 89Ah
 5 hour rate (15.9A, 10.5V)..... 79.5Ah
 1 hour rate (61.3A, 9.6V) 61.3Ah
 Internal Resistance
 Fully Charged battery 77°F(25°C) 5.2mOhms
 Self-Discharge
 3% of capacity declined per month at 20°C(average)
 Operating Temperature Range
 Discharge -20~60°C
 Charge -10~60°C
 Storage -20~60°C
 Max. Discharge Current 77°F(25°C) 800A(5s)
 Short Circuit Current 2000A
 Charge Methods: Constant Voltage Charge 77°F(25°C)
 Cycle use 14.4-14.7V
 Maximum charging current 27A
 Temperature compensation -30mV/°C
 Standby use 13.6-13.8V
 Temperature compensation -20mV/°C

Discharge Constant Current (Amperes at 77°F25°C)

| End Point Volts/Cell | 5min | 10min | 15min | 30min | 1h | 3h | 5h | 10h | 20h |
|----------------------|------|-------|-------|-------|------|------|------|------|------|
| 1.60V | 297 | 204 | 169 | 97.9 | 61.3 | 24.7 | 16.8 | 8.96 | 4.66 |
| 1.65V | 273 | 191 | 161 | 95.0 | 60.9 | 24.1 | 16.6 | 8.94 | 4.62 |
| 1.70V | 248 | 177 | 162 | 92.0 | 61.1 | 23.7 | 16.3 | 8.92 | 4.56 |
| 1.75V | 223 | 164 | 142 | 88.4 | 59.3 | 23.1 | 15.9 | 8.90 | 4.50 |
| 1.80V | 197 | 151 | 133 | 86.7 | 57.4 | 22.5 | 15.6 | 8.85 | 4.43 |

Discharge Constant Power (Watts at 77°F25°C)

| End Point Volts/Cell | 5min | 10min | 15min | 30min | 45min | 1h | 2h | 3h | 5h |
|----------------------|------|-------|-------|-------|-------|-----|------|------|------|
| 1.60V | 512 | 360 | 309 | 186 | 139 | 121 | 67.2 | 48.4 | 33.8 |
| 1.65V | 476 | 342 | 307 | 181 | 136 | 119 | 66.0 | 47.8 | 33.6 |
| 1.70V | 440 | 324 | 294 | 176 | 133 | 118 | 64.8 | 47.3 | 33.4 |
| 1.75V | 405 | 307 | 284 | 170 | 130 | 115 | 63.6 | 46.7 | 33.2 |
| 1.80V | 369 | 287 | 274 | 164 | 127 | 111 | 63.0 | 45.9 | 32.9 |

